

Scale 1 : 500



NOTES:

CIVIC ADDRESS: 311303 HIGHWAY 6, MOUNT FOREST, ON
 ZONING: C4 (COMMERCIAL RURAL)
 DOWN SPOUT LOCATIONS APPROXIMATE

LEGEND:

DS	DENOTES	DOWN SPOUT
FF	"	FINISHED FLOOR
L	"	LANDSCAPED AREA
LS	"	LOADING SPACE
GD	"	GARAGE DOOR

DOWN SPOUT DRAINAGE PIPE

- SEWER BEDDING SHALL BE AS PER OPSD 802.010 FOR FLEXIBLE PIPES.
- DRAINAGE PIPE SHALL BE A COMBINATION OF 75, 125, 150 AND 200mm Ø PVC WITH A SDR 28 RATING. ROOF DRAINAGE TO BE DISCHARGED TO SUB-SURFACE DRAINAGE PIPING AS SHOWN.
- CONCRETE HEADWALL TO BE SET AT OUTLET LOCATION IN ACCORDANCE WITH OPSD 804.030.

PARKING DETAIL

PARKING CALCULATIONS	AREA OF RETAIL STORE	PARKING SPOTS REQUIRED	RATIO
PARKING SPACE 3m x 6m (TYP)	400sqm	20	1 SPACE PER 20sqm
	AREA OF WAREHOUSE/STORAGE	PARKING SPOTS REQUIRED	1 SPACE PER 185sqm
	595sqm	4	
	AREA OF OFFICE	PARKING SPOTS REQUIRED	1 SPACE PER 30sqm
	479sqm	16	
	AREA OF WORKSHOP	PARKING SPOTS REQUIRED	1 SPACE PER 70sqm
	670sqm	10	
LOADING SPACES (PROPOSED BUILDING)	GROSS FLOOR AREA	LOADING SPOTS REQUIRED	SIZE
	595sqm	2	4m x 6m EACH

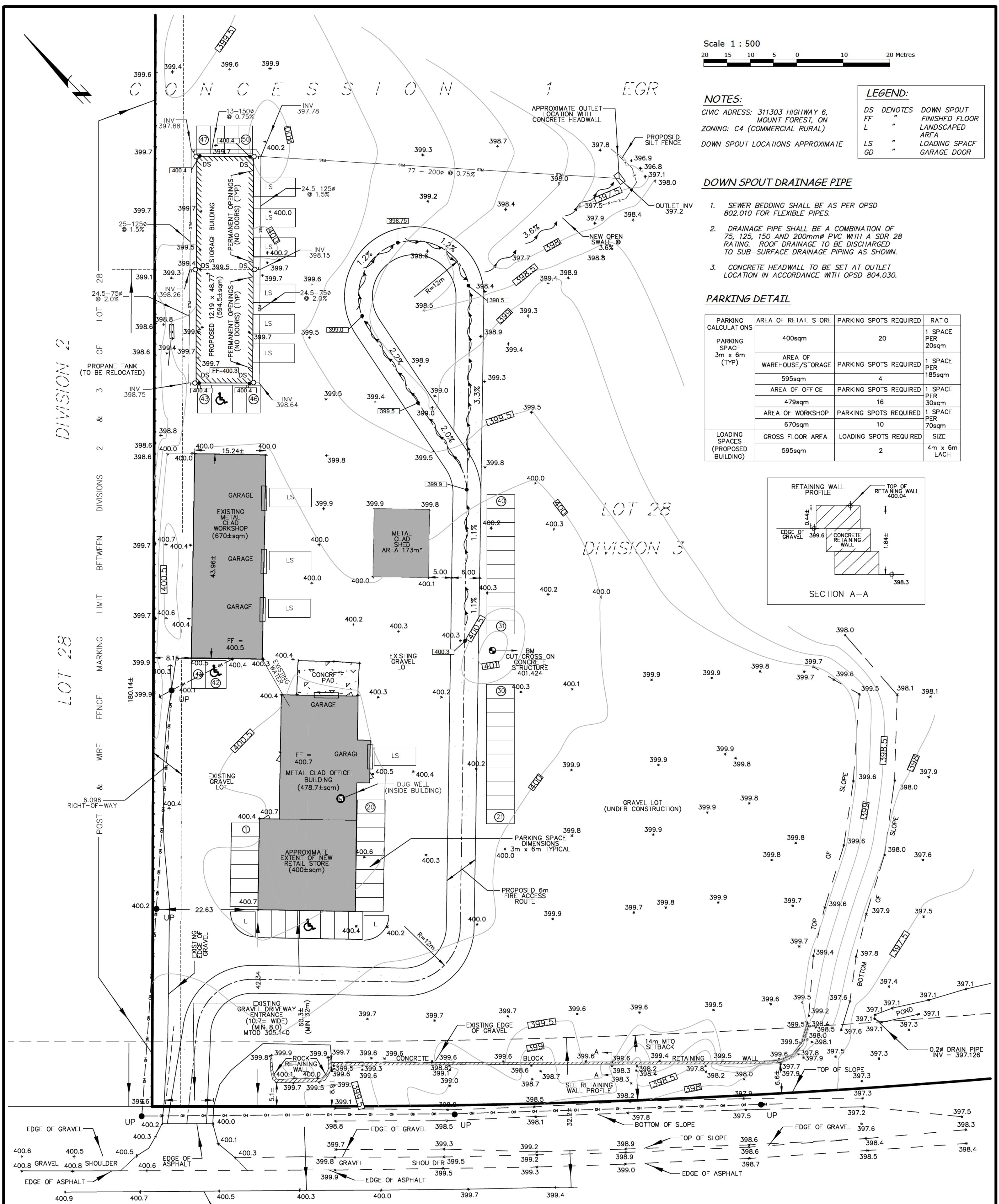
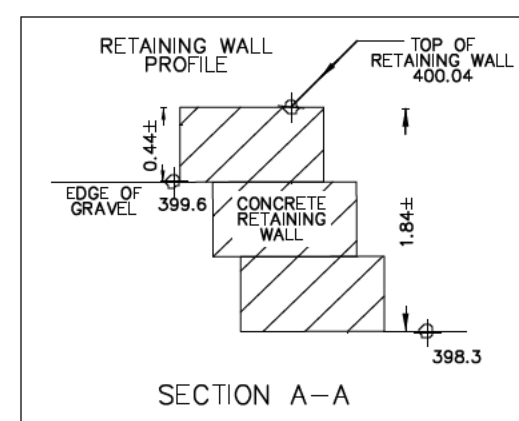

THE LOCATION OF ALL UNDERGROUND AND ABOVEGROUND UTILITIES AND STRUCTURES IS NOT NECESSARILY SHOWN ON THE CONTRACT DRAWINGS, AND WHERE SHOWN, THE CONTRACTOR SHALL INFORM HIMSELF OF THE EXACT LOCATION OF ALL SUCH UTILITIES AND STRUCTURES AND SHALL ASSUME ALL LIABILITY FOR DAMAGES TO THEM.

BENCHMARK NOTE:
 ELEVATION SHOWN ON THIS PLAN ARE GEODETIC AND ARE RELATED TO THE CUT CROSS ON CONCRETE LOADING DOCK, SHOWN HEREON, HAVING AN ELEVATION OF 401.424 METRES. THE TOPOGRAPHICAL DETAIL WAS SURVEYED STARTED JANUARY 24, 2025 BY WILSON-FORD SURVEYING & ENGINEERING

SITE/GRADING & DRAINAGE/SERVICING PLAN

PART LOT 28, DIVISION 3, CONCESSION 1 EGR
 GEOGRAPHIC TOWNSHIP OF EGREMONT
 TOWNSHIP OF SOUTHGATE
 COUNTY OF GREY

REVISED	DESCRIPTION	DRN	CHK	DATE
8	ADDITIONAL ELEVATIONS ADDED		JB	11/26/25
7	PROPOSED BUILDING ADDED, ADDITION TO BUILDING DELETED		JB	10/10/25
6	RETAINING WALLS ADDED		JB	08/11/25
5	ADDITION TO BUILDING & DRIVEWAY		WvDM	07/25/25
4	PARKING SPACES AND LOADING SPACES ADDED		JB	04/07/25
3	GRAVEL DRIVEWAY ADDED		JB	03/24/25
2	COMPLETED BUILDING CORNERS TO THE OFFICE BUILDING		WvDM	02/12/25
1	PARKING SPACES ADDED		JP	02/05/25
0	1ST SUBMISSION - TOWNSHIP OF SOUTHGATE		JB	02/04/25

CLIENT: SOUTHBEND BUILDING SUPPLY

WILSON - FORD
 Surveying & Engineering

PROVINCE OF ONTARIO

DESIGN: GF
 DRAWN: JB

PROJECT No. 25-10094